

EVO + Relay Install Diagram

⚠ PLEASE READ

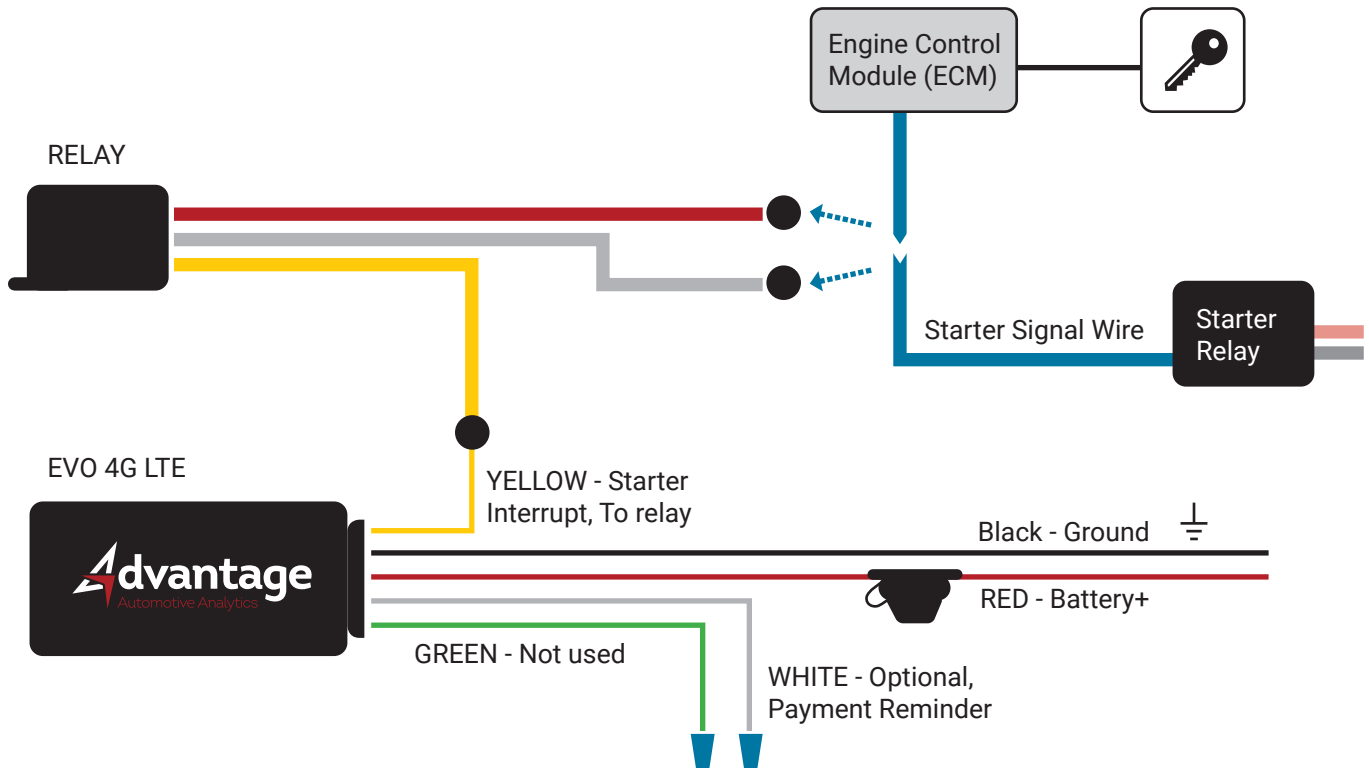

IMPORTANT



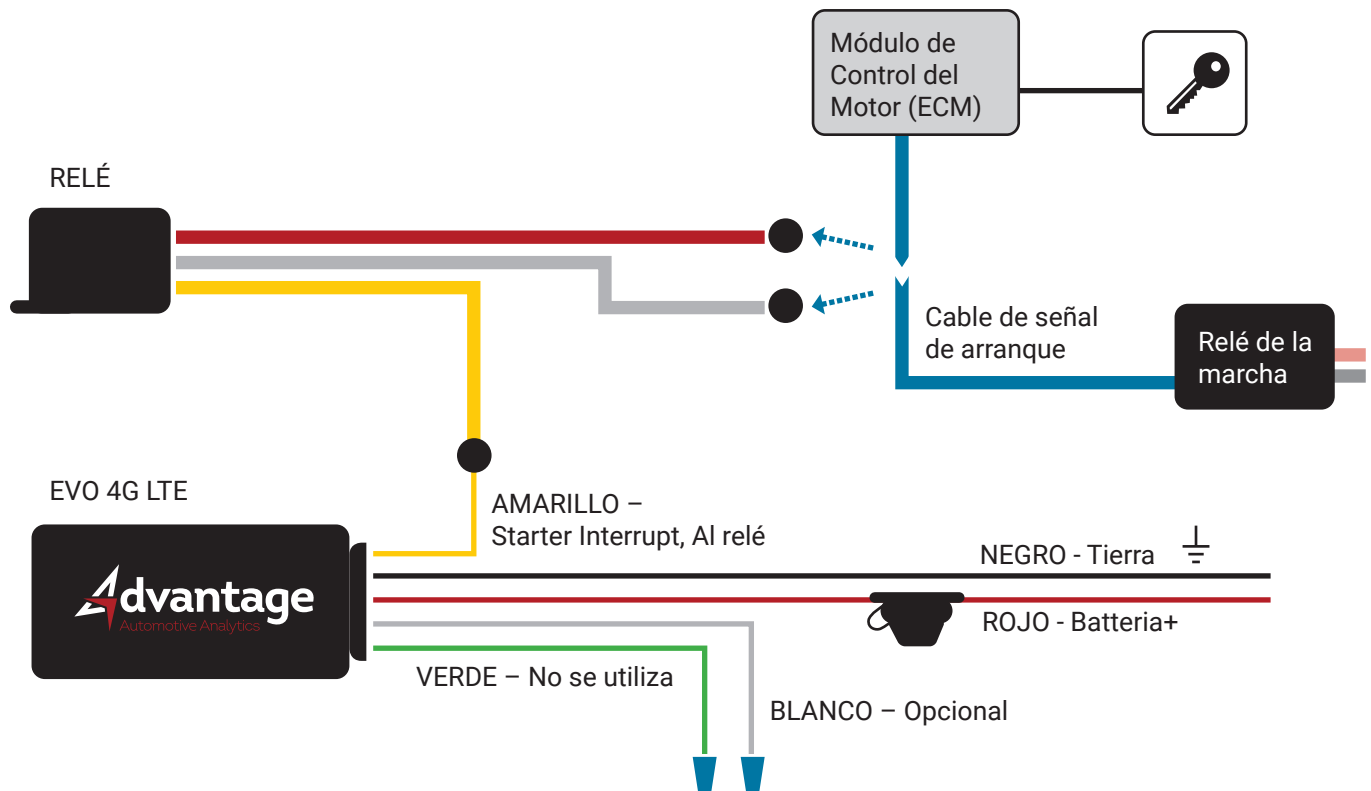

- ⚠ Yellow device harness wire connects to yellow relay wire.
- ⚠ Do NOT splice wire leading from ignition switch to the ECM.
- ⚠ Use voltmeter to ensure red device harness wire is connected to constant power source when vehicle is off.
- ⚠ Make sure all wire connections are completed before plugging device into harness.

Instalación EVO + Relé

! FAVOR DE LEER



IMPORTANTE

-  El cable amarillo del cableado se conecta al amarillo del relé.
-  No corte el cable que corre del arranque (🔑) hacia el ECM (computadora del vehículo).
-  Utilice un voltímetro para asegurarse que el cable rojo del cableado este conectado a una fuente de corriente constante.
-  Asegúrese que todas las conexiones se realicen antes de conectar el cableado al aparato.